

AVL-901(B) GPS Vehicle Tracker Hardware Installation Manual



Table of Contents

I. Working Directions.....	2
II. System Introduction.....	3
III. Wiring and Installation	4
1. Product Parts List.....	4
2. Panel Description.....	5
3. Precaution before Installation	5
4. Installation.....	6
5. Power Charging	9
6. Description of the LED Indicators.....	10
7. Inspection Items after Installation	10
IV. Operating Instructions.....	11
1. Geo-fence (Park) Function.....	11
2. Sound Monitoring Function.....	11
3. Position Report Function	11
4. Tracking Function	11
5. Password	11
V. Hardware Specifications.....	12
VI. Troubleshooting	13

I. Working Directions

Thank you for your purchase of AVL-901(B) GPS/GPRS Tracker. In order to realize the full functions of this product, please read this manual carefully before starting to use the product.

1. This product can only be maintained and repaired by qualified professional service personnel. If you detach this product for maintenance or repair, your warranty will be invalidated.
2. When connecting the other devices, read carefully their instruction manuals, so as to carry out correct installation; do not connect incompatible device.
3. Please use genuine original parts and qualified batteries and peripheral equipments, so as to avoid damage to this product.
4. As this product is a high-tech product, please read carefully this manual before starting to use the product, so as to avoid inappropriate operation.
5. Drivers should not operate this product while driving a vehicle, thereby, affecting safe driving.
6. This product can work properly only when GSM communication is in good condition.
7. Please reduce electromagnetic interference to the product; and use it properly.
8. GPS communication is liable to be affected by environmental shielding; may fail to carry out positioning during certain circumstances. It will resume the positioning function as soon as it leaves the shielding environment. This is normal. Please do not worry when encountering such problem.
9. The position report and the relevant data provided by this product is for reference only.
10. We suggest replacing the stand-by battery each year in order to ensure its normal function.
11. Each signal sent out from the system will be confirmed for successful transmission in the base station of the mobile operator. However, if system stoppage occurs or if the mobile telephone is preset to a switch off state by the customer, it cannot ensure successful transmission.
12. For safety reason, do not tell the other people your AVL-901(B) mobile number, without taking precautions. Otherwise, your privacy may be compromised along with other safety problem.

II. System Introduction

AVL-901(B) is a high-tech product through cooperation with mobile operators. It combines GPS Global Positioning System and GSM/GPRS communication system, which can clearly inform you the position & situation of your car.

GPS is the abbreviation for Global Positioning System, which is a product of the cold war between USA and USSR. During the cold war, USA arranged 24 position location satellites around the earth orbit, in order to measure the space coordinate and time of the measured objects through the triangular location method. These satellites were initially for military purpose. Then, they were allowed to be used for civilian purpose. Their locating precision can be kept within 10 to 15 meters.

GSM is the second digital mobile communication system (GPRS, second and fifth digital mobile communication system), and at present it is the mobile communication system that has the largest coverage and owns the most number of users. This product combines GPS and GSM/GPRS technologies together. It uses GPS system to locate your car, and sends the position/ situation report back to you via GSM/GPRS communication system.

With a delicate microphone, you can monitor the present situation in your car from a faraway place. You can use the telephone remote control function to set monitoring mode, which will report the situation of your car to you periodically.

Following are the function descriptions for the AVL-901(B) products.

1. In-Car Monitoring Function

You can monitor the situation inside the vehicle by make a call (after 5 rings) to the unit; or by sending a short message (100) to the unit; it will return phone call automatically for monitoring action.

2. GPS Position Tracking Function

With this function, the vehicle owner will be able to know the geographic coordinates, speed, direction, and other related information of the car anytime in any place. The report methods can be via SMS short message service, or via GPRS. You can also select a one time report or continuous report (tracking function).

III. Wiring and Installation

1. Product Parts List

- AVL Unit



- GPS Antenna



- GPRS Antenna



- Mini Microphone (optional)



- Back-up Battery (optional)



- RS232-USB Cable (optional)



2. Panel Description

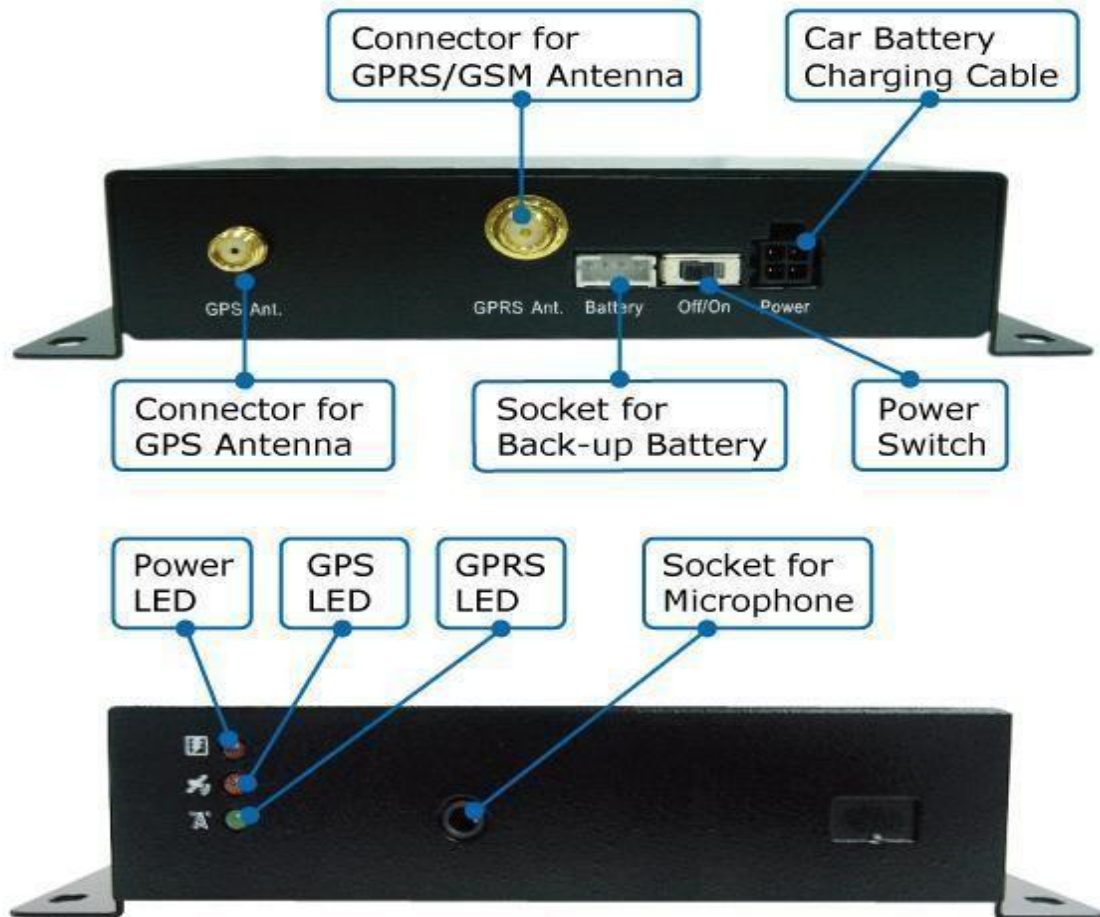

3. Precaution before Installation

- Check if all the parts are included.
- Prepare a SIM card for **GSM** communication. Use some other mobile phone to confirm that the **PIN code** has not been set, and that it can dial out and receive telephone calls without problem.
- Before install the **SIM card**, make sure to cut off power from the AVL unit. The correct installation method is to push the tray completely into the AVL unit, until you feel it is hooked by something.
- Find a suitable place inside the car for installing the unit.
- Check if all the wiring has been connected correctly; then connect the AVL unit to the power source.
- **It takes around over 20 minutes for the very first time positioning.**
- The factory default password is "**8888**".

4. Installation

Step 1: Install GPRS Antenna

- * Connect the GPRS Antenna to the unit.
- * Fasten the connection by turning the screw in the bottom.
Please do not swing round the antenna itself.



Step 2: Install SIM Card

- 1). Unscrew and remove the back cover of your locator.
- 2). Push the holder top upward, as illustrated, to loose it.



- 3). Pull the holder top up.



- 4). Insert the SIM card by sliding it into the card holder slot, with the chip module facing to the connectors on PCB, as shown in the picture.



- 5). Flip down the holder top.

- 6). Push the holder top leftward, and let it snap in completely.



- 7). Put back the bottom cover and screw it up.

- ※ Make sure to turn off the power before install the SIM card.
- ※ Make sure to deactivate the PIN code, so that the SIM card can operate without PIN protection.
- ※ Before install the SIM card to the GPS Tracker, please use a mobile phone to make sure the SIM card can make & receive phone calls without problem.
- ※ Before install the SIM card to the GPS Tracker, please use a mobile phone to empty the SMS storage of the SIM card.

Step 3: Connect GPS Antenna

- < **GPS antenna is used to receive satellite signals in the sky. It should be positioned at a place where it will have an unobstructed view of the sky.** The ideal location is top of the dashboard or close to the rear window of the car.
- < GPS antenna can pick up signals through glass and plastic, but will not “see the sky” through metal or other conductive surfaces. To avoid distractions of GPS signal, make sure the antenna is not covered or shielded by any object containing metal, such as the metallic windshield.
 - < If your car is with metallic windshield, please cut a hole on the windshield
above the place where you put the GPS antenna, so that the antenna can receive the GPS signals.



Step 4: Power On

Connect AVL-901(B) to the power source, After power on, Power LED will light constantly; GPS LED will dark steady orange, or flashing orange (after get a position fix). The device will be ready to work in about 30-45 seconds after turn on the power. To turn off the unit, please just slide the power switch to “OFF”.

※ If AVL-901(B) is connected to the optional back-up battery, the unit will be always ON; power switch will be of no function.

Step 5: Check if GPS can works properly

- < **Method** : When GPS has got position fixed, the GPS LED will turn from constant dark to “blinking light”. Check if the GPS LED has turned to “**blinking light**”.

5. Power Charging

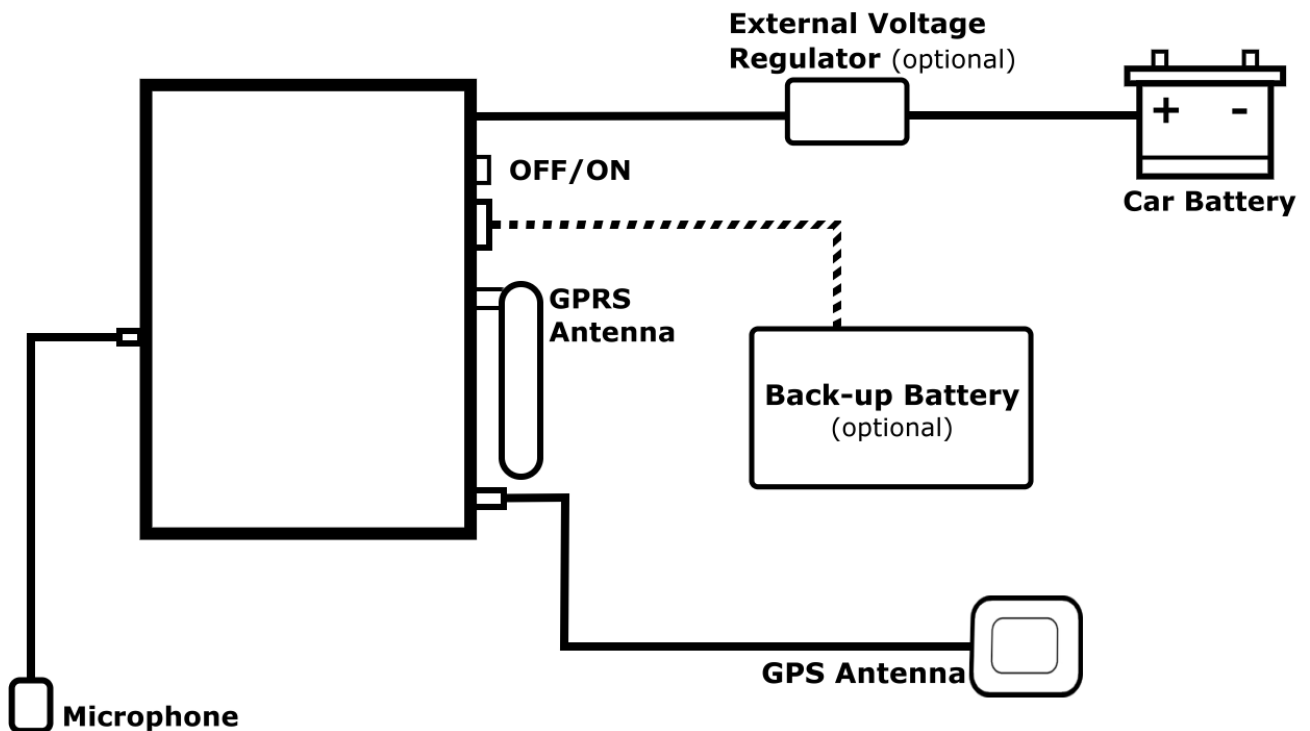

*** This should be done by the professional technician.**

- The AVL unit should be connected to power source, after all the wiring work has been completed and checked.
- **GPS antenna** is used to receive satellite signals in the sky. It should be fixed to face the sky; and should not be covered or shielded by any object containing metal, such as the metallic windshield.
- **Microphone** should be fixed on top of the driver's seat or around the steering wheel.
- Wiring connections must be firm and reliable; and the joints should be wrapped with insulating tape tightly.
- After the microphone have been connected and tested, the joints should be wrapped with insulating tape tightly, so that they will not get loose.
- The unused electrical wire should be properly insulated.
- 4000mA back-up battery can last for 36 hours. For longer operation time, please use a back-up battery with larger capacity.

6. Description of the LED Indicators

	POWER (RED LED)	GPS STATUS (ORANGE LED)	GSM/GPRS (GREEN LED)
Flash	---	GPS is on, and position is fixed	GSM is sending or receiving data
Constant Glow	normal	---	GSM is on, but not yet connected to the network
Constant Dark	in trouble or no power	GPS is not fit	GSM is in the standby mode; or SIM Card was installed improperly; or in trouble

7. Inspection Items after Installation

- After connected to the power source, the **RED LED** indicator should be “constant glow”.
- The **GREEN LED** for GSM/GPRS state should “flash” when sending or receiving data.
- The status of the **ORANGE LED** for GPS state:
 - go to an open air place, check the status of the orange indicator
 - make sure GPS has got position fixed, and the Orange LED “flashes once per second”
 - make a phone call to the AVL unit, and ask it to report its current position
- Complete the installation, and restore the interior of the car.

IV. Operating Instructions

1. Geo-fence (Park) Function

When park your car or leave your valuable asset at a certain place, you can activate “**Park**” (Geo-fence) function to guard it. The unit will send a SMS message to the preset phone number, when someone moves the car or the asset without permission over a preset distance. The accuracy of GPS positioning is liable to be affected by time, weather, and other environmental factors. It is suggested to set the geo-fence range over 200 meters.

2. Sound Monitoring Function

If you want to know what is happening inside the car, you can send a SMS command code **100#Password** to the unit to monitor the situation in the car, LIVE & REAL-TIME.

3. Position Report Function

No matter where you are, when you want to know the position of your vehicle, send a SMS message “**111#Password**” to AVL-901(B); it will report its location back to you by SMS, or GPRS.

4. Tracking Function

Tracking report function can be turned on or off according to the requirements of the user. There are 2 reporting methods: a). **Internet real-time tracking via GPRS**; and b). **SMS message report**.

Note: Tracking function will continually report vehicle position until it is turned off.

5. Password

Password is the key to operate AVL-901(B) GPS Tracker. It is a **4-digit data**. The default password is “**8888**”. Be sure to change the password after the installation, and keep it firmly in mind.

Note: In order to protect your privacy, do not tell others the password, unless it is necessary. Please change the password, if it has been known by the persons who you do not want them to access the data.

V. Hardware Specifications

Dimensions	135x76x25 (mm)
GSM/GPRS Module	Siemens TC65
Bandwidth	EGSM900: TX880-915MHz, RX 925-960MHz DCS1800: TX 1710-1785MHz, RX 1805-1880MHz GSM850: TX824-849MHz, RX 869-894MHz GSM1900: TX1850-1910MHz, RX 1930-1990MHz
Maximum RF Output Power	EGSM900, GSM850: 33 dBm(2W) GSM1800, GSM1900: 30 dBm(1W)
Resistance	50Ω
Transmission Speed	Circuit switched 4.8/9.6 kbps
Frequency	L1, 1575.42MHZ
Channels	20
Position Accuracy	10 meters CEP without SA
Speed Accuracy	0.1 meters/second, without SA
Coordinate System	WGS-84
Hot Start	< 8 Seconds
Warm Start	< 38 Seconds
Cold Start	< 60 Seconds
Height	18000 meters (60000 feet) max.
Speed	515 meters / second (1000 knots) max.
Acceleration	4g max.
Working Voltage	12 to 24 VDC
Power Consumption in stand-by mode	1W (power save mode)
Power Consumption in working mode	2W (working mode)
Housing	Metal
Operation Temperature	-20°C to +70°C
Storage Temperature	-30°C to +80°C
Humidity	0~95%, non-condensing

VI. Troubleshooting

1. After AVL-901(B) installed, why there is no response?

- Check the polarity of power connection to see if a wrong polarity connected.
- Check the connection of back-up battery to see if it is properly installed.
- Check the power is on or not.

2. Why does GSM fail to communicate?

- Check if the SIM card has been activated
- Check whether the SIM card has password
- Check if the SIM card is correctly placed.
- Make sure the SIM card does support GPRS function.
- Make sure to cut off power, before pulling out the SIM card.
- If the vehicle is parked in a place where the GSM signal is weak.
- GSM base station of the mobile operator is crashing.
- Whether this SIM card is suspended (such as forget to pay the bill...)

3. Why GPS can not get a position fix?

- Check if GPS antenna is correctly installed; if the GPS antenna is put in a proper place, faces the open air.
- Make sure there is not be any metal shield, such as windshield heat insulation paper with metallic content, on top of the GPS antenna - which may block the reception of GPS signal.
- Do not park your vehicle under shielding or under a building.
- If necessary, put the GPS antenna on top of the car roof temporarily.

4. Why does GPS positioning take such a long time?

The time requires to get a position fix can be affected by many factors, such as the weather, distribution of clouds, roadside trees, elevated roads, nearby high buildings, heat insulating papers containing metal elements, and even the covering of the hands, may affect the reception effect of satellite signals. Besides, positioning the vehicle in an idle state will take shorter time than positioning it in motion state.

5. Does the weather affect GPS operation?

GPS system is able to overcome weather problem in its initial design. GPS satellite positioning signals consist of short waves; the transmission of short waves will not be affected by weather conditions. GPS signals may produce error factors during transmission, such as solar wind, earth rotation, variation of atmosphere density, building reflection, etc. All of which may cause deviations to GPS short wave affect signals. But weather factors will not affect the normal function of GPS.

6. Why can not it monitor the sound real-time?

- Check the microphone connector whether it was connected properly or not.
- Check the memory for SMS messages in the SIM card, to see if it is full.
- Can not receive GSM signal in the place where you locate.

7. No warning message when the car is moved.

- Out of power.
- Park button is off.
- The car is moved within the restricted area.