



www.mor-star.com

GAS Spring monitor Arm

Model# MS-LCD100 , **UP to 23" inch LCD**



GAS SPRING MONITOR ARM

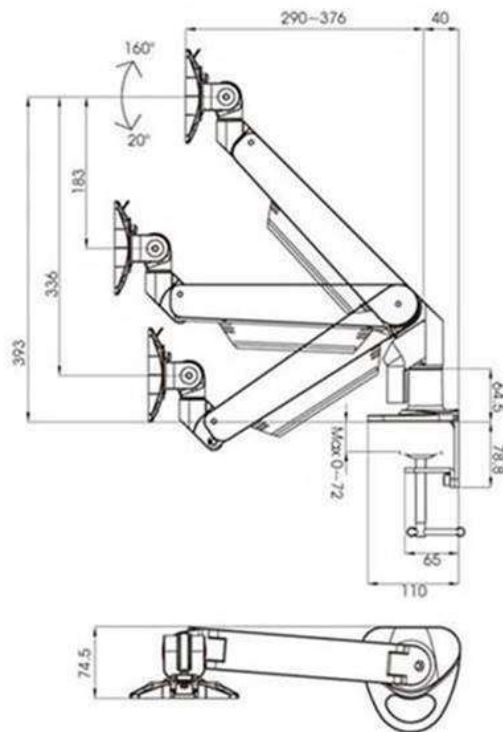

LCD-100 Weight Range 2.8~7.8kg (6.2~17.1LBS)
Desk clamp and grommet mount options
Single lcd arm, rotates available at 2 joints
Simply move monitor to desired position
Includes quick-install/quick-release VESA mechanism for monitor
Adjustable tilt 160 degrees up and 20 degrees down
Cable management reduces workplace clutter
VESA-Monitor compatible - 75mm & 100mm

Key Specifications/Special Features /

SINGLE ARM

FOR VESA MOUNTING 75/100MM

WEIGHT CAPACITY : 2.8~7.8KG

TV SIZE : SUPPORT UP TO 23"LED

ADJUSTABLE TILT 160° UP AND 20° DOWN

SWIVEL LEFT AND RIGHT ADJUSTABLE

DESK CLAMP AND GROMMET MOUNT OPTIONS

ROTATES AVAILABLE AT 2 JOINTS

SIMPLY MOVE MONITOR TO DESIRED POSITION

INCLUDES QUICK-INSTALL/ QUICK-RELEASE VESA MECHANISM FOR MONITOR

CABLE MANAGEMENT REDUCES WORKPLACE CLUTTER

Model # MS-LCD -120 --/121 --- GAS spring single monitor ARM



GAS SPRING MONITOR ARM



Weight Range
LCD-120 1.7~5kg (3.7~11LBS)
LCD-121 2.8~7.6kg (6.2~17.1LBS)

Mount lcd to wall
 Single lcd arm, rotates available at two joints
 Simply move monitor to desired position
 Includes quick-install/quick-release VESA mechanism for monitor
 Adjustable tilt 160 degrees up and 20 degrees down
 Cable management keeps cables tucked beneath arm
 VESA-Monitor compatible 75mm & 100mm
 Optional ACC-228 wall plate available allows up/down movable

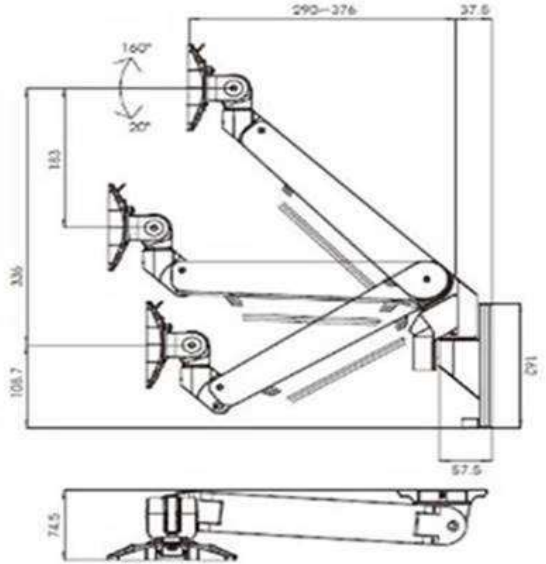

GAS Spring monitor Double Arms --model : LCD130 /131



Weight Range
LCD-130 1.7~5kg (3.7~11LBS)
LCD-131 2.2~8.2kg (4.8~18LBS)

Mount lcd to wall
 Dual lcd arm, rotates available at 3 joints
 Simply move monitor to desired position
 Includes quick-install/quick-release VESA mechanism for monitor
 Adjustable tilt 160 degrees up and 20 degrees down
 Cable management keeps cables tucked beneath arm
 VESA-Monitor compatible 75mm & 100mm
 Optional ACC-228 wall plate available allows up/down movable

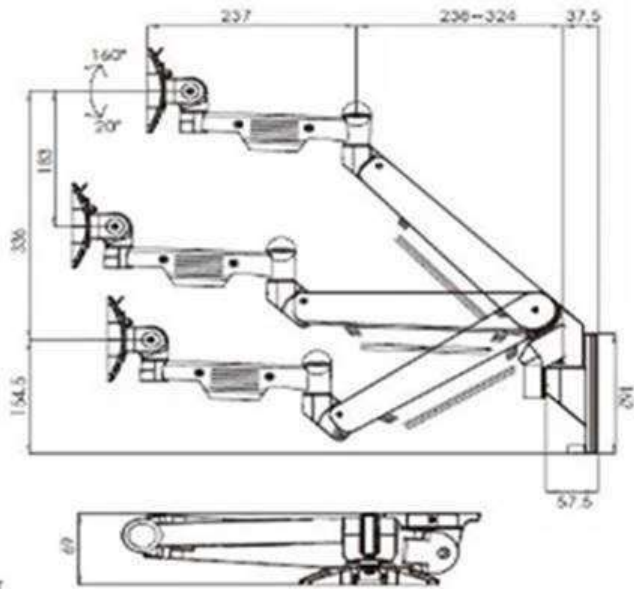

GAS spring monitor double Arms

Model # LCD110- Gas spring double Arm

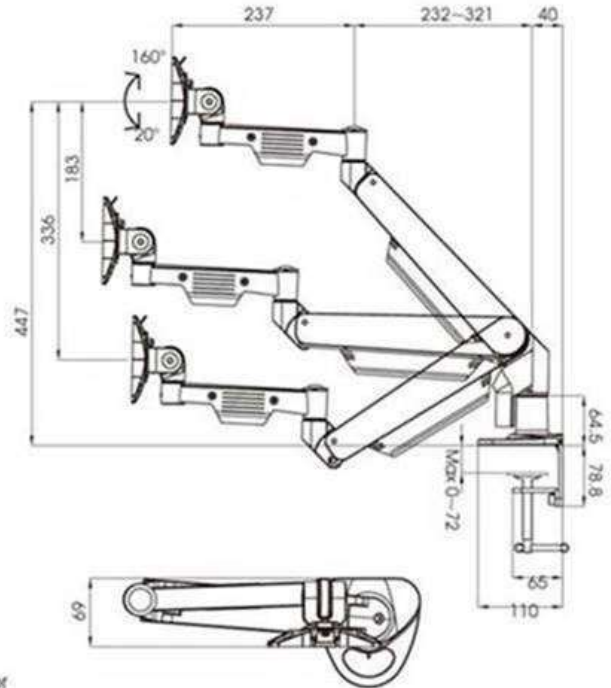

LCD-110 Weight Range
2.2~8.2kg (4.8~18LBS)
Desk clamp and grommet mount options
Dual lcd arm, rotates available at three joints
Simply move monitor to desired position
Includes quick-install/quick-release VESA mechanism for monitor
Adjustable tilt 160 degrees up and 20 degrees down
Cable management reduces workplace clutter
VESA-Monitor compatible - 75mm & 100mm

Key Specifications/Special Features /

DOUBLE ARM

FOR VESA MOUNTING 75/100MM

WEIGHT CAPACITY : 2.2~8.2kgs

TV SIZE : **SUPPORT UP TO 23"LED**

ADJUSTABLE TILT 160° UP AND 20° DOWN

SWIVEL LEFT AND RIGHT ADJUSTABLE

DESK CLAMP AND GROMMET MOUNT OPTIONS

ROTATES AVAILABLE AT 2 JOINTS

SIMPLY MOVE MONITOR TO DESIRED POSITION

INCLUDES QUICK-INSTALL/ QUICK-RELEASE VESA MECHANISM FOR MONITOR

CABLE MANAGEMENT REDUCES WORKPLACE CLUTTER